

Memo

Type of product	PJ-103		
Date of purchase			
Name		Tel	
Address			

PERFECT WATER SERIES

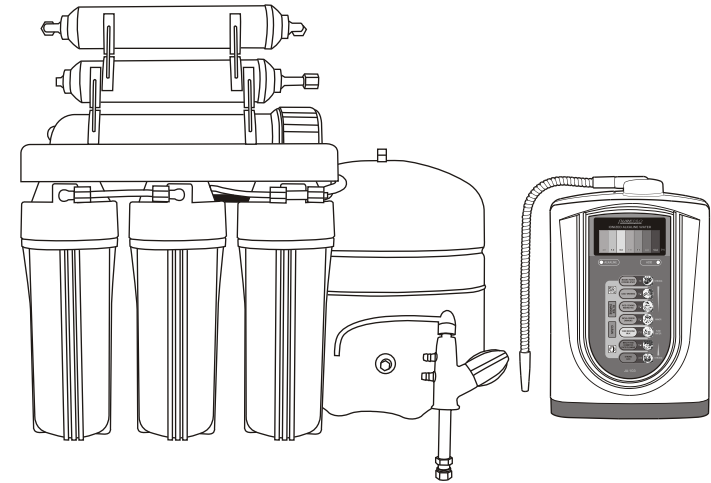

PJ-103 USER'S MANUAL

01	About perfect water	11	Installation diagram
03	Why perfect water is popular	13	Change filters
04	Components	16	Change membrane
05	Cartridge filters	17	Trouble shooting guide
07	Preparation	18	FAQ
08	Panel operations and functions	19	Memo
10	Tubing connection diagram		

Thank you very much for selecting Pure-Pro Water Corp.

In order to bring the best use of your system, please read the user's manual carefully before installation and follow the regulations.

About Perfect Water

PurePro® Perfect Water Series (RO + Water Ionizer)

More and more people understand that the "perfect water" system would combine the purity of Reverse Osmosis (R/O) and the tremendous benefits provided by alkaline, ionized water. Historically this has not been easily achieved for a variety of reasons. Our water technology experts at PurePro have solved the problem of combining these two phenomenal yet very different water technologies. Now you can have perfectly clean AND perfectly healthy water by installing RO system with water ionizer!

Features

- Four levels of alkaline water.
- Two levels of acid water, including super-oxide.
- Filter water (non-ionized) - by Reverse Osmosis Water System
- Stainless steel output spout
- Built-in auto-flushing electrode.
- Unique post-operation automatic and silent cleansing for extended lifespan
- Voice confirmation every time you select a different pH level
- Filter change required indicator
- Easy 1-minute change filter compartment
- Optional ability to connect direct to plumbing and operate under mains pressure
- 3.2 Gallons NSF Standards Water Storage Tank.
- FDA Approved Polypropylene Made Flat Cap Housing.
- Automatic Shut-off Valve, Mini Flow Restrictor, Stainless Steel Check Valve.
- Special & Beautiful Water Ionizer faucet
- Feed water connector, drain saddle valve.
- Four Color Coded 1/4 inch Tubing for System Connection
- Completely Assembled
- 100% Factory Tested and Sterilized Ready for Installation.
- Installation Instruction.

Specifications: (Reverse Osmosis)

- Model: EC106-Alkaline
- Membrane: 50 GPD/ 189 LPD
- Operation pressure: 50 - 100 PSI
- Dimensions: (cm) 37 (L) x 20 (W) x 45 (H) - System
(cm) 28 (L) x 28 (W) x 35 (H) - Tank
- Weight: 8 kg - system
4 kg - tank

FAQ

Q: What is the guarantee on the PurePro system ?

The PurePro system (excluding filters) is guaranteed for 1 year for material and workmanship. All defective parts will be replaced free within the first year under natural breakdown. The membrane has one year pro-rated guarantee.

Q: What factors affect the quantity and the quality of the water production?

There are four major variables to consider:

1. **Pressure**-The greater the water pressure, the better water quantity and quality it produced. Water pressure of 60 PSI is ideal.
2. **Temperature**-76°F is the ideal water temperature for R.O. 40°F water will cause the production of R.O. water to fall to half of that at 76°F. The maximum water temperature recommended is 85°F.
3. **Total Dissolved Solids (TDS)**-The higher the amount of dissolved contaminants in the water, the lower the quantity of water produced. A high level of TOTAL DISSOLVED SOLIDS can be overcome with additional water pressure.
4. **Membrane**-Different membranes have different characteristics. Some produce more water than others; some have better contaminant rejection capabilities; some have greater resistance to chemical abrasion for longer life. PurePro system includes TW30-1812-50 The Thin Film Composite (TFC) membranes combine the best of these characteristics and are considered the finest membrane in the world.

Q: What is the maintenance schedule for the PurePro system ?

The three pre-filter cartridges should be changed every 6 months. The 5 micron sediment cartridge filter is the first one; the second is a carbon cartridge filter, and the third one is a 1 micron sediment filters. (some systems comes with the Extruded carbon filter.) Failure to change the cartridge every 6 months may cause chlorine to destroy the membrane.

Q: What does the PurePro series drinking water taste like?

The taste of the PurePro water depends on the amount of contaminants in the tap water originally. If 95% of dissolved minerals and chemicals are removed, the R.O. water may taste like distilled water (no minerals), bottled water (low mineral), or natural spring water (moderate mineral content).

Trouble Shooting Guide

Phenomenon	Reason for problems and handling guideline
Power background light not on displays nothing	Ensure power cord is connected to an electrical outlet
Back light is not on and nothing get displayed when generating	1. Water pressure too low, the machine does not work correctly, operator installs additional water pump. 2. Check for correct installation of filter cartridge. The machine does not work when filter cartridge is misplaced. Unfold the bent part of the water supply hose.
Ionized water or pure water come out dirtily	1. Maybe it is time to replace filter cartridge? (Filter cartridge can be bought in distribution agencies) 2. Is the tap only half on? Please let more water flow out from the tap. 3. Is water supply line frozen? Defrost the water supply line before using. Is the indicator light for cleaning required on? Please perform cleaning.
Electrolyzed alkaline water appears to have white colored stain	Alkaline ionized water is usually white color after being generated. This is due to the air bubbles formed as a result of reaction with electrolysis. It will turn into transparent in a short while and is perfectly safe for drinking.
Container for storing alkaline water shows white floating object or develops thin layer on its inner wall	1. The white floating object is a crystal formation (the solid form of calcium) which reaction of Calcium ion and Carbon Dioxide in the air generates. It is perfectly safe for drinking. 2. The thin layer that can be seen is the solid form of Calcium. Please use vinegar to clean it.
Not using the ionizer for long period of time	Please ensure the power cord is unplugged. Remove water separator and filter device from the purifier.
Alkaline water flowing out from alkaline faucet becomes slower and slower	Maybe gradual formation of Calcium crystal in hose blocks the water outlet, which makes the water flow-out become slower and slower. Please consult with a professional to clean inner hose or purchase special filter cleanser for the ionizer from our company.

About Perfect Water

Specifications: (Water Ionizer)

Model	JA-103
Power supply	AC: 220V/50HZ(customized product)110V/60HZ
Power consumption	100-200W
ORP level	+500MV ~ -400MV
Electrolysis material	Nanometer titanium alloys electrolysis trough
In-water pressure	1 ~ 6.5kg/cm ²
Electrolysis technique	Continuous electrolysis technique (water volume and temperature gauge built-in)
Machine protection installation	Fuse 10A and electrical board: 2A electrical power overheating protection installed, transformer temperature protection installed.
Electrolysis	Processing rate of water 2./minute: [In-water pressure is 0.1Mpa(about 1kgf/cm ²)] Water exit volume 3L/minute: [In-water pressure is 0.2Mpa(about 2kgf/cm ²)](estimate) Electrolysis capacity level: Alkaline 3 level; Acidic 1 level Possible continuous electrolysis duration: (Level 1~2) about 1 hours (Level 3) about 30 Plate cleaning automatically performs every time being used. When intensive cleaning is required after a period of time, Intense cleaning indicator is on. Automatic back cleaning when tap water is closed after processing.
Main machine dimension	Height 315mm x Width 275mm x Depth 140mm
Machine weight	About 3.5kg
Purifier	Total water flowing volume: about 12000L Purifying capacity: take away salty particle residue Remove foul and bad odor
Max. water temperature for continuous usage	40°C
Power cable length	About 9 feet

Why Perfect Water is Popular

Water Ionizer is a medical device in Japan.

Why? Read on . . .

ALKALINE WATER IMPROVES CHRONIC HEALTH CONDITIONS

Research in Japan since the 1950's and testimonials indicate the following conditions have been improved from drinking alkaline water:

- Arthritis
- Heartburn
- Chronic fatigue
- Indigestion
- Leg cramps
- High blood pressure
- Poor circulation
- Migraines
- Nausea
- Obesity
- Osteoporosis
- Psoriasis
- Stress

Dr. Otto Warberg received the Nobel Prize for discovering the **cause of cancer** - this being lack of oxygen which is **low alkaline pH**. No disease can exist in an alkaline environment. Japanese medicine has proven this over the last 15 years. Water ionizer can restore proper alkaline pH within weeks.

Change Membrane

Change membrane: (Reverse Osmosis)

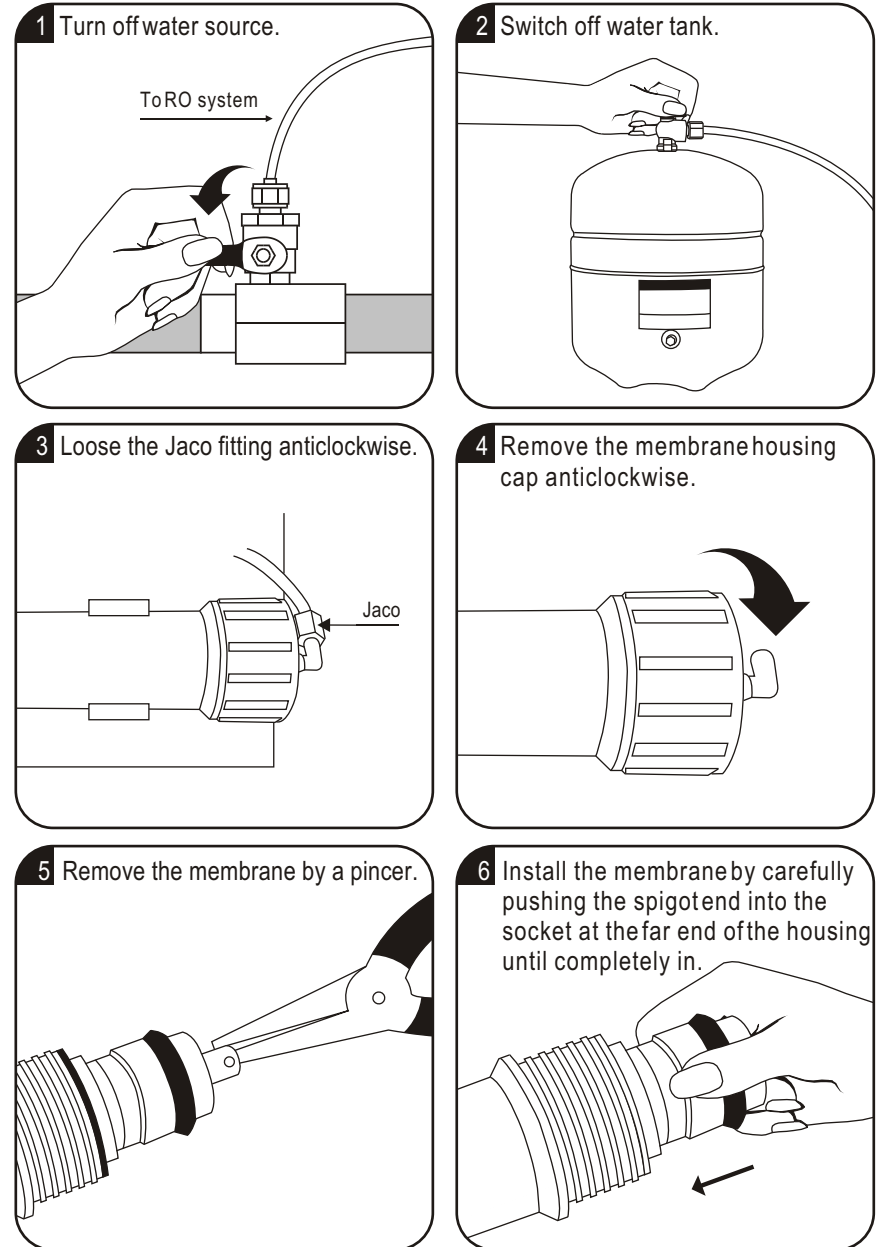

Change Filters

Change filters: (Reverse Osmosis)

1 Prepare a housing wrench.

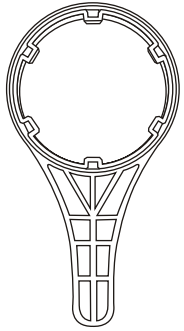

2 Turn off water source.

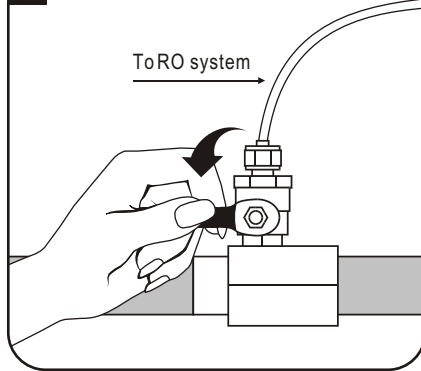

3 Switch off water tank.

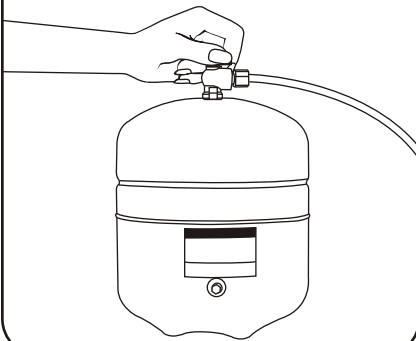

4 Open housings clockwise with a wrench.

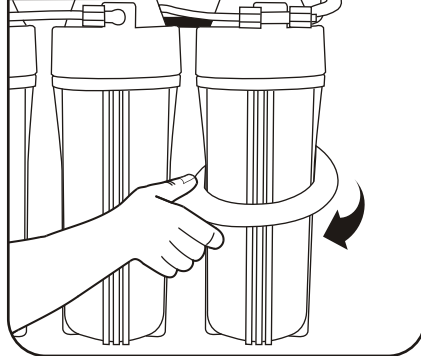

5 Put the replacement filters in the housings and double O'ring.

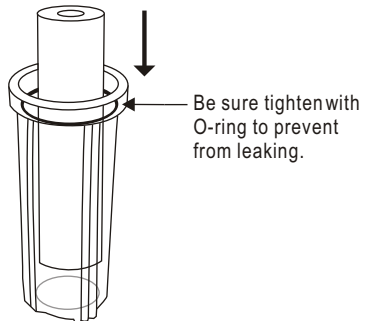

6 Drain out 1 Gallon of water to purify replacement filters.

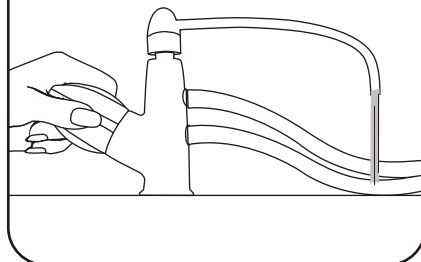

Components

Components: (Water Ionizer)

1 Snake hose x 1



2 Hose clip x 2

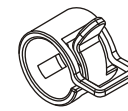

3 PH testing liquid 10ml



4 Water inlet/ Outlet hose x 2

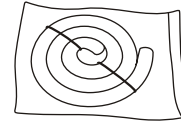

5 Hanging fixture x 1

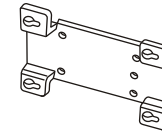

6 Suction used to fix water drain hose

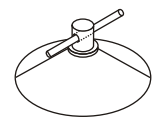

7 Water Ionizer faucet x 1

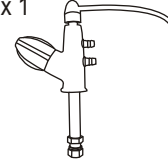

Components: (Reverse Osmosis)

1 Tankball shut-off valve x 1

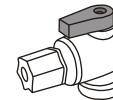

2 Water storage tank x 1



3 Housing wrench x 1

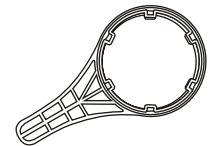

4 Deliver-valve x 1
Water supply connector x 1

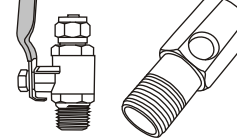

5 Drain saddle x 1

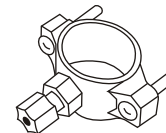

6 Tubing x 1

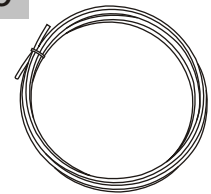

Cartridge Filters

Cartridge filters: (Water Ionizer)

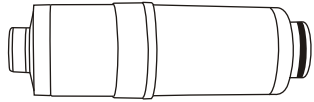

Type: Carbon filter

Main parameter: Filter life 12000L

Water pressure 0.1M pa~0.4M pa

Water quality: Meet the requirement of "Sanitary safety and function criteria of drinking water machine" (2001).

Water source: Municipal tap water

Things to note: Replace filter regularly (The filter life can last for one year at most. If clogged, it is necessary to replace the filter.)

Cartridge filters: (Reverse Osmosis)



(Stage 1) 5 Micron Sediment Filter

This 5 micron sediment filter is made of 100% pure polypropylene fibers. High capacity filter removes dusts, particles and rusts. (Service Life: 6 Months)

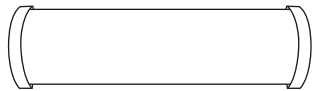

(Stage 2) Block Carbon Filter

This block carbon filter is composed of high-performance carbon that removes free chlorine, odor, organic contaminants, pesticides and chemicals that contributed to taste and odor. (Service Life: 6 Months)



(Stage 3) 1 Micron Sediment Filter

This 1 micron sediment filter is made of 100% pure polypropylene fibers. High capacity filter removes dusts, particles and rusts. (Service Life: 6 Months)

Change Filters

Change filters: (Water Ionizer)

To replace the filter, turn off the water and switch off the ionizer unit by the mains and unplug it. Then remove the unit from the wall where it is attached.

1. open the cover of filter.
2. Twist the cartridge filter anticlockwise. Then pull up the cartridge filter.
*note: the body of ionizer shall stay up-right to prevent water from coming into the system.
3. Inset a new cartridge filter. Twist the filter clockwise and lock it securely.
4. It is recommended that the extended cleaning programmed be run to check for leaks.

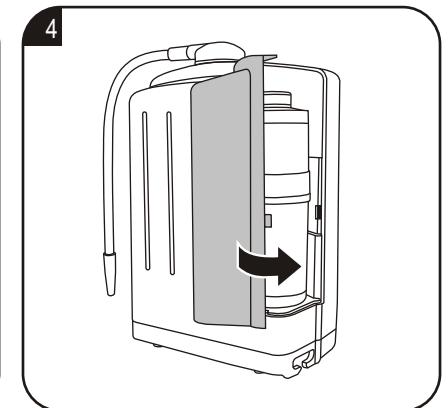
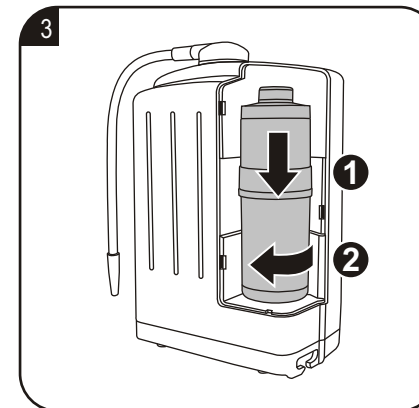
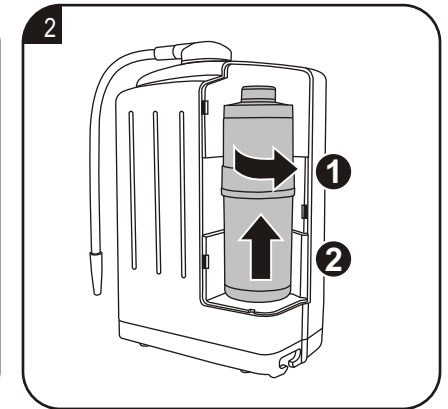
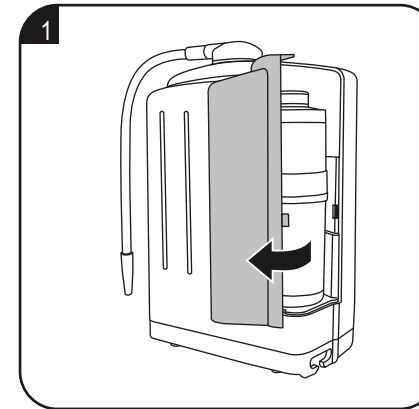

Change Filters

Change filters: (Water Ionizer)



Cleaning Button

When intense cleaning light is on, please turn the tap on, press start button, cleaning light flickers and music is played. After cleaning is done, cleaning light goes off, music stops, the everyday drinking button is selected by default.



Replacement Signal Rest Button

1. When replacement light goes on, the filter cartridge has exceeded total water flow volume; it must be replaced immediately to ensure electrolysis water quality.
2. After the filter cartridge is replaced, press and hold Replacement Signal Reset Button for 3 seconds. When you hear a long hua sound and replacement light goes off, release the button.

When using 50L water, indicating light goes on, which means to require cleaning. It can be adjusted according to different water condition in regions. The procedures are as follows:

When waiting, 1. press and hold "purified Water Selection" button for 5 seconds, water flow volume 50L is revealed on the top left-hand part of the screen. 2. Adjustable range is from 30L to 90L by use of "cleaning" button or "replacement" button (plus or minus). 3. After range adjustment is over, press "cleaning" button once again, so the setp is completed.

ACF Feature activated carbon pores structure
(High-technology long-life coconut shell fiber activated filter cartridge)

Type of Material: silver fiber coconut shell activated carbon	
Flowing Rate: 5.0L/Minute	
Purifying Capacity: take away salty particle residue	
Flowing Volume: about 12000L Remove foul and bad odor	

Cartridge Filters



(Stage 4) TFC Membrane

Made in USA. High rejection TFC type membrane with the capacity of producing 50 gallons per day. This membrane removes the following hard water contaminants that may be present in your water: lead, copper, barium, chromium, mercury, sodium, cadmium, fluoride, nitrite, nitrate, and selenium. (Service Life: 2 Years)

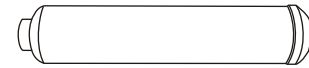

(Stage 5) Post Carbon Filter

NSF approved. This post carbon filter is designed to improve taste. It removes any residual impurities and odors from the tank and provides a finer conditioning of pure water. (Service Life: 1 Years)

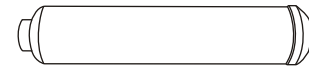

(Stage 6) Alkaline Filter

The Alkaline filter changes the acidic RO water into a perfect Natural Alkali Calcium Ionized Water. The Alkaline filter simply gives back minerals such as ionized calcium, magnesium, sodium, potassium ion, which were taken away while purifying the water. (Service Life: 1 Years)

Preparation

Preparation: (Water Ionizer)

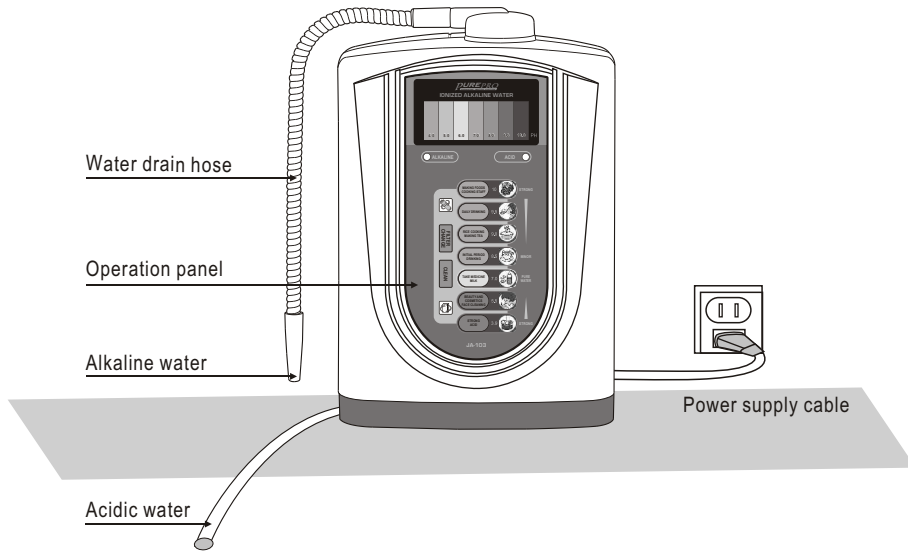

Preparation: (Reverse Osmosis)

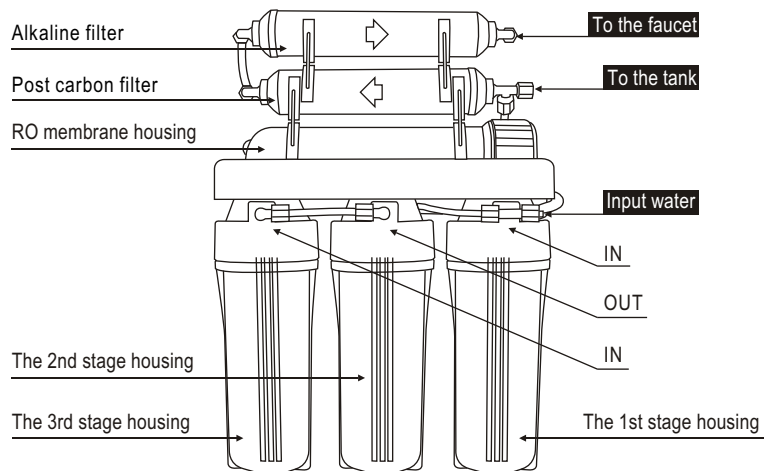

Installation Diagram

Flexible hose :

Simply cut a sufficient length of hose to reach "acidic water output" port. Allow some extra length in the event of acidic water to be collected for external or plant use.

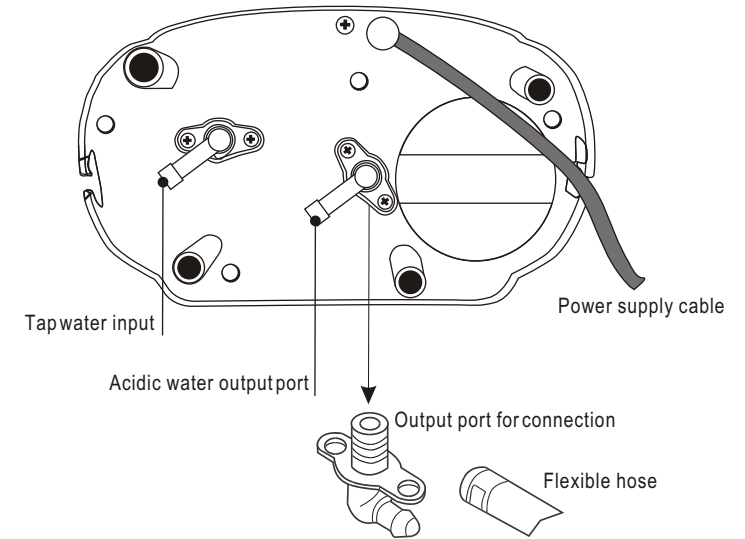

Installation Diagram

Input water :

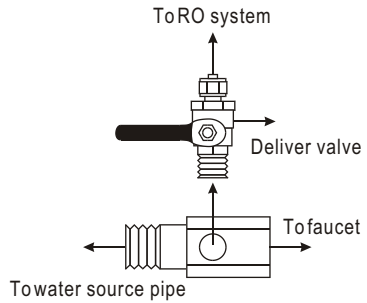

Install water tank :

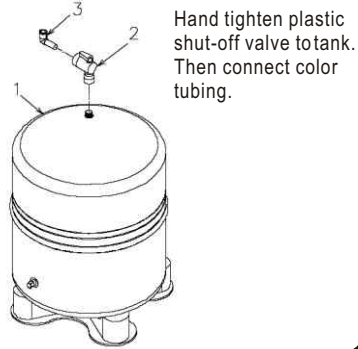

Install faucet :

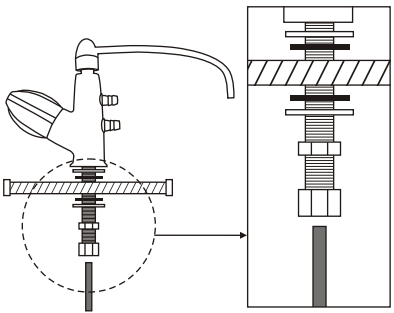

Install drain saddle :

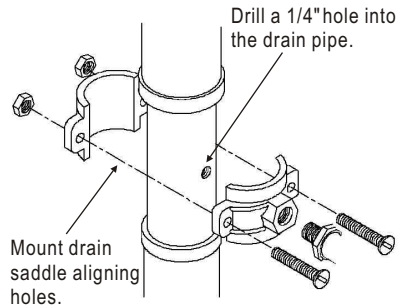

Assemble membrane :

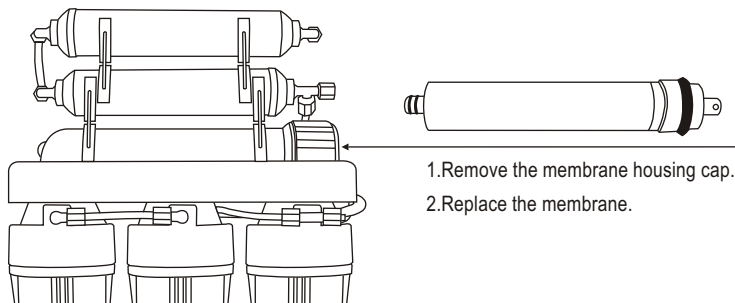

Panel Operations and Functions

Alkaline Water Selection Button
(Select different intensity alkaline water according to different needs)

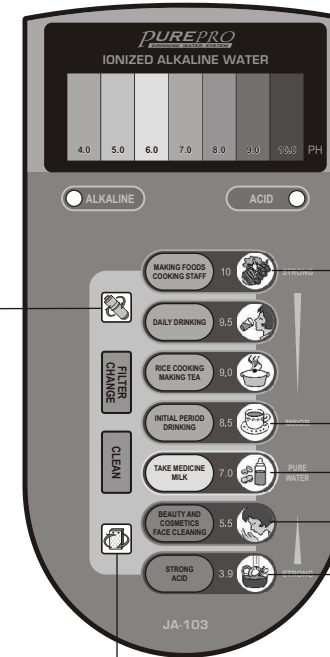

Replacement/life
(Filter Cartridge Replacement Indicator When replacement light goes on, it indicates the filter's life is over. Replacement Signal Reset Button)

Purified Water Selection Button

Acidic Water Selection Button

Cleaning Button

(When the light is on, please press start button to begin intense internal cleaning; the machine will begin cleaning automatically when it's filled with 60L water)

Panel Operations and Functions

Alkaline Water

1. Generation of Alkaline Water: turn the tap on and water flows into the machine. During processing back light goes on, buzzer beeps 3 times and arrow indicator points toward Alkaline water. Press the selection button for the required PH level. With different press, PH value size varies. Purple colored back light represents heavy alkaline, blue colored back light represents everyday drinking alkaline.

Purified Water

2. Generation of purified Water: when the button is pressed, water flows into the machine. Arrow indicator points toward purified water, buzzer beeps 3 times; both alkaline and acidic water outlet are without electrolysis (green colored back light goes on). After the tap is closed for about 1 minute, back light goes off and the everyday drinking button  is automatically triggered on by default.

Acidic Water

3. Generation of Alkaline Water: when the button is pressed, water flows into the machine. Buzzer beeps continuously (back light becomes red). Arrow indicator points toward Acidic. Press the selection button for the required PH level. With different press, PH value size varies. After the tap is closed for about 1 minute, backlight goes off and the everyday drinking button  is automatically triggered on by default.

Notice: when alkaline calcium ionized water generation stops each time, computer in the machine automatically performs internal cleaning. When done, back light goes off, the machine is in a state of power saving.

Tubing Connection Diagram

CONNECTING THE COLOR TUBING:

- A. Connect the WHITE tubing to the water supply connector.
- B. Connect the BLUE tubing to the sink top faucet.
- C. Connect the BLACK tubing to the drain saddle.
- D. Connect the RED tubing to the storage tank.

